



REDI CONTROLS, INC.

Installation Operation & Maintenance Manual

Literature File No. 1047-02

RuptureAlarm™ Model RA-2-3

ALARM for use on
RS & NRS Series
RuptureSeal™
Backup Relief Valves



.....for Low Pressure Centrifugal Chillers

R-11

R-113

R-123

Revised Technically as of November 15, 1995
This Copy was Printed as of January 19, 2004
© 1994 REDI CONTROLS, INC. GREENWOOD, INDIANA

Table of Contents

	Page
GENERAL INFORMATION	4
Specifications	5
Installation Kit	6
Field Provided Items	6
General Overview	6
INSTALLATION	7
Mounting (Steps 1 thru 3)	7
Illustration - <i>RuptureAlarm™ Mounted on RS Series Valve</i>	7
Illustration - <i>RuptureAlarm™ Mounted on NRS Series Valve</i>	7
Electrical Connections (Steps 4 thru 7)	8
<i>Wiring Diagram - Power Supply Hook-up</i>	8
<i>Wiring Diagram - Remote Alarm</i>	8
MAINTENANCE	9
Setting Pressure Point for Alarm	9
Illustration - <i>Internal Parts Layout</i>	9
Annual	9
Test Procedure	9
Troubleshooting	10
Troubleshooting Chart	10
Parts List	10
Service Log	11
Warranty	Back Page

GENERAL INFORMATION

**YOU ARE URGED TO READ THIS MANUAL COMPLETELY BEFORE
INSTALLING AND/OR OPERATING THIS UNIT**

Upon Receiving Your Unit

Inspect the unit for possible damage caused during shipping. **Contact Equipment Servicing before attempting to use a damaged unit.** (800) 626-8640 or (317) 865-4130.

Warnings and Cautions

***NOTE:** Warnings and Cautions appear in highlighted boxes as illustrated below at appropriate points throughout this manual. Give special attention to these items.*

Warnings: are provided to alert you to potential hazards that could result in serious personal injury and damage to your equipment. Warnings may appear in this manual or on the equipment. Heed all Warnings.

Cautions: are designed to alert you to situations that may result in damage to your equipment.

Personal safety and the proper operation of your equipment require strict observance of these precautions.

**EQUIPMENT SHOULD BE INSTALLED AND OPERATED ONLY BY
QUALIFIED PERSONNEL**

Warning: Certain servicing procedures may expose you to harmful materials and dangerous conditions. To minimize the possibility of injury, follow safety procedures and instructions described in this manual, on product labels and in material safety data sheets provided.

***NOTE:** The manufacturer has a continuous equipment improvement policy and reserves the right to change specifications and design of its products without notice.*

Specifications

Electrical Power Requirements: 103-127 VAC, 60 Hz.
Will also work with: 99-121 VAC, 50 Hz
Remote Alarm Relay Maximum Contact Rating: 220 VAC; 1 Amp

Operating Environment: 40°F to 120°F
Storage Environment: -20°F to 120°F

Dimensions (approximate): 5 ¾" height x 2¾" width x 2" depth

Weight (approximate): 2 pounds

Shipping weight (approximate): 3 pounds

Installation Kit

Kit includes:

One (1) Pre-assembled RA-2-3 **RuptureAlarm™**

Sufficient copper Connecting Tube and Fittings
to connect Pressure Switch to Valve in any
installation configuration

One (1) Mounting Bracket

Two (2) Bracket Mounting Screws (*screws used with installation
of NRS Series only*)

One (1) Installation, Operation & Maintenance Manual

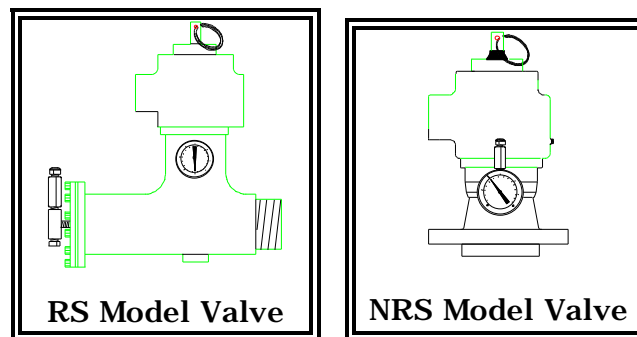

Field Provided Items

Electrical Conduit

Wiring

General Overview

The **RuptureAlarm™** is designed to be used with a **RuptureSeal™** backup relief valve. The function of the **RuptureAlarm™** is to alert the operator that either an over pressurization condition has occurred due to a burst rupture disk, or there is pressure build up between the **RuptureSeal™** and the rupture disk due to leakage through a defective rupture disk.

The **RuptureAlarm™** will activate when the preset (operator adjustable) pressure setting is exceeded providing a visual alarm to the operator. The visual indication (a neon lamp) will remain latched “ON” until manually canceled, even if the pressure subsides. The neon lamp remains activated to insure that the operator is made aware that an alarm event has occurred.

The **RuptureAlarm™** also provides a set of SPDT contacts for remote alarm indication.

INSTALLATION

Warning: DO NOT attempt to install a damaged unit!

Mounting (Steps 1 thru 3)

NOTE: See Illustrations below for mounting *RuptureAlarm™* on both the **RS Series** and **NRS Series RuptureSeal™** Valves.

- 1a. **RS Series Valves:** Remove two (2) flange cover cap screws (4) and attach alarm bracket to chamber cover (5).
- 1b. **NRS Series Valves:** Using the two (2) ¼" slotted-head bracket mounting screws provided, attach alarm bracket to valve flange. (42).
2. Remove hex plug from alarm port (35).
3. Fabricate a connector tube (49) from the tubing and fittings supplied with the unit to connect **RuptureAlarm™** to Alarm Port (35). Make sure all joints are leak tight. (The **RuptureAlarm™** is shipped pre-set to 5 psig - (see *Alarm Set-point Adjustment* on page 9 to change setting).

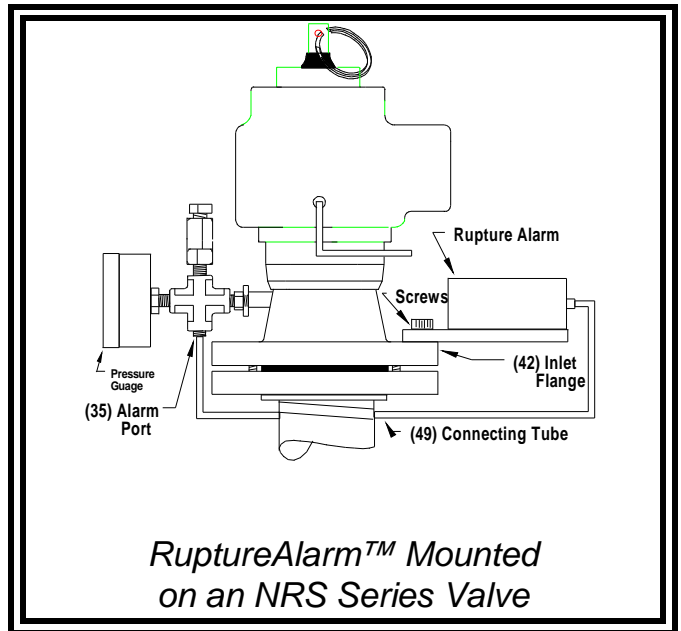
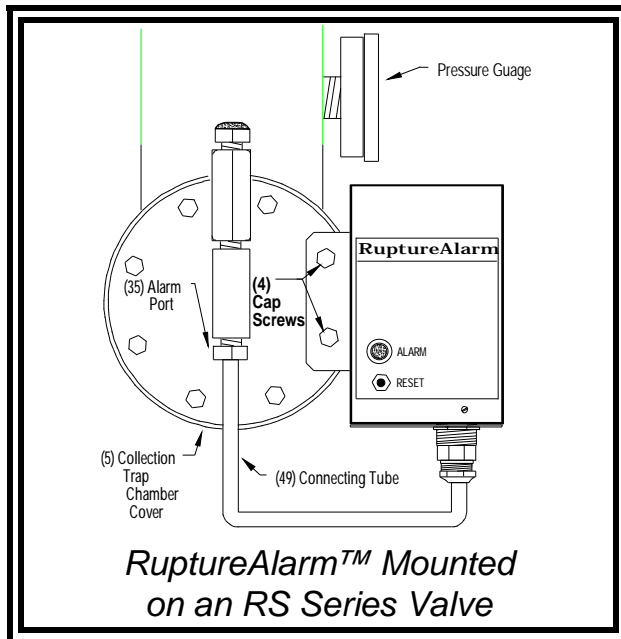

NOTE: The above illustrations are only examples of typical connecting tube installations. Use your discretion in mounting your unit, utilizing any combination of the fittings supplied with the alarm.

Electrical Connections (Steps 4 thru 7)

Warning: Open and lock out all electrical disconnect switches to prevent electrical shock while performing this part of the installation.

The **RuptureAlarm™** requires two power connections from the chiller's control circuit.

Electrical requirements are **103-127 VAC, 60 Hz or 99-121 VAC, 50 Hz**

NOTE: Use class 1, 18 AWG copper wire and metal conduit. All field installed wiring must comply with all applicable NEC and local electrical codes.

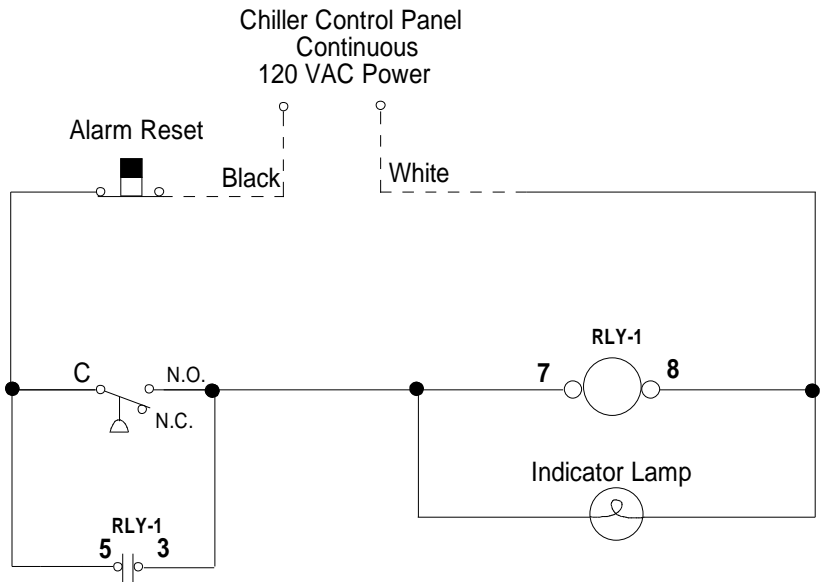

Wiring Diagram -
Power Supply
Hook-up

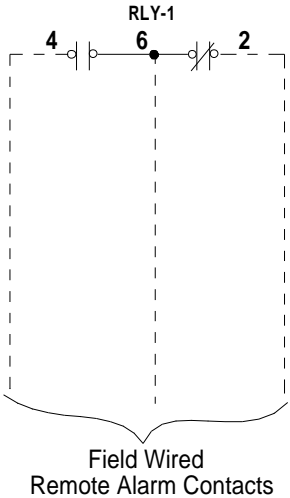

Wiring Diagram -
Remote Alarm

4. Open and lock out all electrical disconnect switches providing power to the chiller control panel.
5. Using wire nuts, connect the field installed power supply lines from chiller control panel to the BLACK & WHITE flying leads provided in the **RuptureAlarm™** enclosure. **BE SURE THE POWER SUPPLY IS CONSTANT AND INDEPENDENT OF CHILLER RUN STATUS** (see Illustration above).
6. Connect remote alarm (if used) to RLY-1 Relay Terminals 2, 4, & 6.
7. Re-close all electrical disconnect switches opened in Step 5.

MAINTENANCE

Alarm Set-Point Adjustment

Use the “*Control Thumb Wheel*” to change the 5 psig factory set-point to a different pressure setting (refer to Internal Parts Layout).

- Rotating thumb wheel clockwise (CW) increases setting.
- Rotating thumb wheel counter clockwise (CCW) decreases setting.

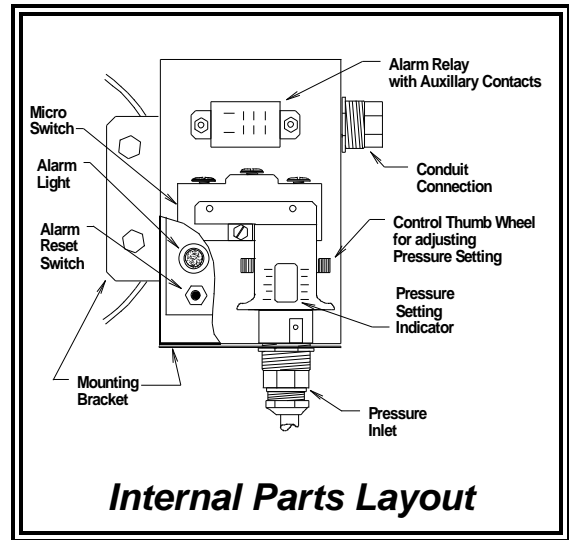

Annual

1. Perform **RuptureAlarm™** test procedure (see below).
2. Inspect the pressure switch connecting tube fittings for tightness at both the pressure switch and at the **RuptureSeal™** connections.

Test Procedure

To test the **RuptureAlarm™** for proper operation, remove the connecting tube from the **RuptureSeal™** alarm port (35), then slowly apply pressure to the pressure switch until the pre-selected pressure setting is exceeded. If the alarm circuit is operating properly, the neon “alarm” lamp will be energized. Press reset switch to reset alarm. If there is a problem, refer to *Troubleshooting Chart* on page 10.

Troubleshooting

Should an operational difficulty or malfunction occur, the diagnostic chart below should help you to quickly determine the cause and corrective action. The Troubleshooting Chart has a "Symptom" column which describes what the unit is doing; a "Cause" column which identifies possible sources of the problem; and a "Solution" column which describes what must be done to correct the problem.

Troubleshooting Chart

Symptom	Cause	Solution
Alarm does not energize when pressure is applied.	1. No power to alarm 2. Pressure switch setting too high 3. Pressure switch defective	Restore power Reset pressure setting Replace switch
Pressure switch contacts make but light does not energize	1. No power to alarm 2. Light defective 3. Defective RLY-1 Relay	Restore power Replace light Replace Relay
Alarm fails to remain energized	Defective RLY-1 Contacts	Replace RLY-1 Relay
Alarm will not reset	1. Defective reset switch 2. Alarm relay RLY-1 contacts stuck	Replace switch Replace relay

Parts List

1. Reset Switch RA-2-3 (RS1)
2. Neon lamp RA-2-3 (NL)
3. Alarm relay RA-2-3 (RLY1)
4. Pressure Switch RA-2-3 (PS)
5. Mounting bracket RA-2-3 (MB)
6. Pressure switch connecting tube RA-2-3 (CT-RS) - (For hook-up to RS-Series Valve)
7. Pressure switch connecting tube RA-2-3 (CT-NRS) - (For hook-up to NRS-Series Valve)

Service Log

Date of Service: ____/____/____ **Technician:** _____
Mo. Day Year (Name or Initials)

Comments:

Date of Service: ____/____/____ **Technician:** _____
Mo. Day Year (Name or Initials)

Comments:

Date of Service: ____/____/____ **Technician:** _____
Mo. Day Year (Name or Initials)

Comments:

Date of Service: ____/____/____ **Technician:** _____
Mo. Day Year (Name or Initials)

Comments:

Date of Service: ____/____/____ **Technician:** _____
Mo. Day Year (Name or Initials)

Comments:

Date of Service: ____/____/____ **Technician:** _____
Mo. Day Year (Name or Initials)

Comments:

REDI CONTROLS, INC.

Equipment Warranty

Within one year after date of purchase, REDI CONTROLS will repair any Redi Controls product being used by the original purchaser, which is defective due to faulty materials or workmanship. REDI CONTROLS has the right to repair or replace a defective part or replace the entire product.

To file a Warranty claim on any system or component, return the defective unit to the address below, or other location as REDI CONTROLS directs, freight prepaid.

This Warranty does not apply to or cover:

Damages beyond REDI CONTROLS' control.

Malfunctions that result from failure to properly install, operate or maintain a product in accordance with instructions provided by REDI CONTROLS.

Failures of equipment due to abuse, accident or negligence.

Damages from, or part failures due to equipment not being installed per REDI CONTROLS' instructions, per applicable codes or ordinances, or in accordance with good trade practices.

Labor or other charges incurred in removing or reinstalling any REDI CONTROLS product or part.

Damages resulting from use of a REDI CONTROLS product for any purpose other than for which it was designed and manufactured.

Any implied warranty of merchantability or fitness for any particular purpose, occurring after the Warranty Period.

Loss of use, loss of time, inconvenience, rental for substitute products, loss of business, loss of income, or any other consequential damages resulting from use or failure of any REDI CONTROLS product.

Inquiries to: REDI CONTROLS at 755 E. Main Street, Greenwood, Indiana, 46143

REDI CONTROLS, INC.
(317) 865-4130