

TROUBLE SHOOTING

Should an operational difficulty or malfunction occur, the diagnostic chart and checkout procedures on the following pages should help to quickly determine the cause and corrective action. The Troubleshooting Chart has a "Symptom" column which describes what the unit is doing; a "Possible Cause" column which identifies possible sources of the problem; and a "Solution" column which describes what must be done to correct the problem.

NOTE: Should the OAM Purger shut down on a **FAULT** condition, DO NOT POWER OFF THE PURGER until you have first removed its electrical panel cover and recorded the status of the green indicator LED's D1 through D5 located on the Logic Board. Knowing the particular LED(s) that are lighted will help you diagnose the cause of the problem. Once the unit is powered off, this information will be lost. Retain the record of the LED readings. Examine the purger for any apparent problems, check the troubleshooting section for possible causes of the fault. Check to see if all appropriate Dip Switches on SW1 & SW2 are off (see pages 33, 39 & 42), then if there is no apparent problem, reset power. See if the fault repeats.

Using Switch SW2 Dip Switches as a diagnostic aid

Switch SW2 Dip Switches can be used to activate the solenoid valves and distillation heater for various procedures. This can be very helpful when diagnosing and or correcting certain operational problems. By switching the appropriate DIP Switch to the **ON** position, the corresponding valve or heater will energize.

1. **SW2** switching **Dip Switch 1 ON**.....energizes **Fill Solenoid (SOL-1)**, **Green D1 LED** will be on **solid**.
2. **SW2** switching **Dip Switch 2 ON**.....energizes **Equalization Solenoid (SOL-2)**, **Green D2 LED** will be on **solid**.
3. **SW2** switching **Dip Switch 3 ON**..... energizes **Oil Return Solenoid (SOL-3)**, **Green D3 LED** will be on solid.
4. **SW2** switching **Dip Switch 4 ON**.....energizes the **Distillation Heater** and the **Green D4 LED** will be on **solid**.

WARNING: Be sure DIP Switches, 1, 2, 3 and 4 on Switch SW2 are returned to the **OFF** position when finished. If any of these DIP Switches are left in the ON position, the OAM Purger will not function properly. (See Fig. 6, page 33 for location of Switch SW2.)

Trouble-shooting Chart

Symptom	Possible Cause	Solution
Power switch ON but switch Light is Off.	Main power to unit Off. Switch light defective.	Restore main power. Replace Switch.
Power switch ON and lighted but Logic Board LED's are all OFF.	Logic Board fuse blown. Logic Board defective.	Replace fuse. Replace Logic Board.
D5 green LED flashing	Chiller Run Signal requirement enabled and no Run signal received	Restore chiller Run Signal
Fault Red LED D6 flashing Green LED D1 ON solid. Indicates distillation tank temperature did not drop below 155 degrees F in the first 20 minutes of the fill phase.	Distillation heater stuck on. (Possible logic board RLY-4 contacts stuck). Temperature Sensor TS-1 defective. Chiller's charging valve closed. Fill Sol 1 failed to open Oil Return Solenoid Valve SOL-3 defective Oil sump valve is closed Refer to "Distillation Tank will not fill" Symptom troubleshooting chart.	Replace Logic Board. Replace sensor. Open valve. Replace solenoid valve. Replace solenoid valve Open valve Refer to "Distillation Tank will not fill" Symptom troubleshooting chart.
Fault Red LED D6 flashing Green LED D2 ON solid. Indicates distillation temperature failed to reach 155 Degrees F within 6 hours after starting Primary Distillation Phase.	Distillation heater defective. Heater relay RLY-4 on Logic Board defective. Temperature Sensor TS-1 defective. Fill Solenoid valve (SOL-1) fails in open position Tank may be oil logged (check sight glasses to determine if oil logged): Oil-logging may be caused by Equalization check valve may be defective and not retaining sufficient pressure in tank to push back oil. Or the Oil sump valve may be closed	Replace heater (see Maintenance Using Switch SW2 dip switch 4 as a diagnostic aid See page 42). Replace Logic Board. Replace Sensor. Replace valve Clear Oil Logging (see page 48 for procedure to clear oil logging)
Fault Red LED D6 flashing Green LED D3 ON solid. Indicates purger Logic Board detected that Purger reached programmed distillation temperature too soon, indicating the OAM Purger not filling properly, or is losing the OAM Purger charge prior to proper distillation. Refer to "Distillation Tank will not fill" Symptom below in troubleshooting section.	Dip Switches on Switches SW1 or SW2 may be set improperly. Pay particular attention to SW2 dip switches 6 and 8 and make sure they are definitely OFF Fill Solenoid Valve (SOL-1) or Oil Solenoid Valve (SOL-3) defective Tank may be oil logged (check sight glasses to determine if oil logged): Oil-logging may be caused by Equalization check valve may be defective and not retaining sufficient pressure in tank to push back oil. Or the Oil sump valve may be closed Defective temperature sensor TS 1	Verify that all dip switches on SW1 and SW2 are in the OFF position. (See pages 33, 39 & 42 for SW1 and SW2 information.) Replace appropriate defective Solenoid Valve Clear Oil Logging (see page 48 for procedure to clear oil logging) Replace Equalization check valve Open oil sump valve Replace temperature sensor

Trouble-shooting Chart (continued)

Symptom	Possible Cause	Solution
<p>Fault</p> <p>Red LED D6 flashing Green LED D4 ON solid.</p> <p>Indicates the Logic Board sees a signal from the Liquid Level High Sensor for longer than 2 hours straight.</p>	<p>Liquid Level Sensor defective Check Logic Board for loose connection to INPUT 2</p> <p>Logic Board may be defective</p> <p>OAM may be oil logged</p> <p>Bleed resistor wire lead between IN2 and Neutral on logic board may be defective or disconnected</p>	<p>Check the Liquid Level Sensor for defect. See pages 46 & 47 for test procedure</p> <p>, Replace logic board</p> <p>SEE Oil will not transfer from Distillation Tank to oil sump, in Symptoms below in this Chart And (see page 48 for procedure to clear oil logging)</p> <p>Correct as needed</p>
<p>Distillation Tank will not fill, or empties too soon during distillation phase.</p>	<p>Chiller's refrigerant charging valve closed or obstructed.</p> <p>Vapor return line stop valve closed.</p> <p>Distillation Heater stuck ON during Fill Phase.</p> <p>Equalization line wrongly sharing a port on the evaporator with another device (such as a non-condensable Purger) that discharges liquid or vapor refrigerant into the evaporator.</p> <p>Equalization line, if connected to Shrader valve, may not have valve stem removed.</p> <p>Fill line kinked or obstructed.</p> <p>Fill line strainer clogged.</p> <p>Fill Solenoid (SOL-1) fails to open.</p> <p>Equalization Solenoid (SOL-2) failed to open.</p> <p>Purger may be mounted too high.</p> <p>Fill line and connecting piping up to evaporator shell may not be insulated causing vapor lock.</p> <p>Refrigerant Charge low.</p> <p>Dip Switches on Switches SW1 or SW2 may be set improperly.</p> <p>Purger Logic Board may be defective</p> <p>Liquid Level Sensor may be defective Indications may be D6 Fault light and/or D3 and/or D4 green LED activated</p> <p>Oil return Solenoid 3 stuck open causing undistilled refrigerant to be forced into oil sump</p>	<p>Open Valve or replace valve.</p> <p>Open Valve.</p> <p>Defective TS-1, Replace. Or RLY-4 contacts stuck. Replace Logic Board.</p> <p>Isolate the equalization line from all such devices (see WARNING in Vapor line hookup instructions on page 16.</p> <p>Remove Shrader Valve Stem</p> <p>Correct as needed.</p> <p>Replace Fill line Strainer.</p> <p>Replace Fill Solenoid (SOL-1).</p> <p>Replace Equalization Solenoid (SOL-2).</p> <p>See installing the Purger Page 13.</p> <p>Insulate, (see page 16 for warning information on insulating.)</p> <p>Correct Refrigerant Charge. (See pages 33, 39 & 42 for SW1 and SW2 information.)</p> <p>Replace Logic Board</p> <p>Check the Liquid Level Sensor for defect. See pages 46 & 47 for test procedure. Also check Pressure Equalization Check Valve for leaking</p> <p>Replace oil return Solenoid 3</p>

Trouble-shooting Chart (continued)

Symptom	Possible Cause	Solution
<p>Heater fails to heat.</p> <p>See using Switch SW2 Dip Switches as diagnostics aid on page 42 (dip switch 4)</p>	<p>Defective Heater.</p> <p>RLY-4 relay defective.</p> <p>Disconnected lead.</p> <p>Defective Temperature Sensor TS-1 Contacts stuck closed.</p> <p>Defective Logic Board.</p>	<p>Replace heater (See Maintenance Section on Using Switch SW2 DIP switch 4 as a diagnostic aid. See page 42 for SW2 information)</p> <p>Replace Logic Board.</p> <p>Reconnect lead.</p> <p>Replace Sensor.</p> <p>Replace Logic Board.</p>
<p>Fill Solenoid Valve (SOL-1) fails to open or close</p> <p>See using Switch SW2 Dip Switches as diagnostics aid on page 42 (Dip switch 1)</p>	<p>SOL-1 Solenoid Valve defective.</p> <p>RLY-1 relay defective.</p> <p>Disconnected lead.</p> <p>Solenoid seat may be contaminated</p>	<p>Replace valve.</p> <p>Replace Logic Board.</p> <p>Reconnect lead.</p> <p>Replace Solenoid</p>
<p>Equalization Solenoid Valve (SOL-2) fails to open or close.</p> <p>See using Switch SW2 Dip Switches as diagnostics aid on page 42 (Dip switch 2)</p>	<p>SOL-2 Solenoid Valve defective.</p> <p>RLY-2 relay defective.</p> <p>Disconnected lead.</p> <p>Solenoid seat may be contaminated</p>	<p>Replace valve.</p> <p>Replace Logic Board.</p> <p>Reconnect lead.</p> <p>Replace Solenoid</p>
<p>Oil transfer Solenoid Valve (SOL-3) fails to open or close.</p> <p>See using Switch SW2 Dip Switches as diagnostics aid on page 42 (Dip switch 3)</p>	<p>SOL-3 Solenoid Valve defective.</p> <p>RLY-3 relay defective.</p> <p>Disconnected lead.</p> <p>Solenoid seat may be contaminated</p>	<p>Replace valve.</p> <p>Replace Logic Board.</p> <p>Reconnect lead.</p> <p>Replace Solenoid</p>
<p>Oil will not transfer from Distillation Tank to oil sump.</p> <p>Or procedure to follow if unit is oil logged Clear Oil Logging (see page 48 for procedure to clear oil logging)</p>	<p>SOL-3 Solenoid Valve defective.</p> <p>Oil Sump valve closed.</p> <p>Oil return line kinked or blocked.</p> <p>Oil Filter blocked.</p> <p>Logic board RLY-3 relay defective.</p> <p>Equalization Solenoid Valve SOL-2 stuck open or leaking past valve seat.</p> <p>Pressure Equalization Check Valve defective and leaking and not retaining pressure for oil push back</p> <p>Oil Check Valve CK-1 stuck closed</p> <p>Tank may be oil logged (check sight glasses to determine if oil logged): Oil-logging may be caused by Equalization check valve may be defective and not retaining sufficient pressure in tank to push back oil. Or Oil sump valve may be closed</p>	<p>Replace valve.</p> <p>Open Valve.</p> <p>Correct as necessary.</p> <p>Replace oil filter.</p> <p>Replace Logic Board.</p> <p>Replace valve.</p> <p>Replace Pressure Equalization Check Valve</p> <p>Replace oil Check Valve CK-1</p> <p>Clear Oil Logging (see page 48 for procedure to clear oil logging)</p>

FOR INFORMATION ABOUT FACTORY REPAIR 317-865-4130

TROUBLESHOOTING THE LIQUID LEVEL SENSOR

Preliminary Test:

- 1) Turn OAM Power Switch OFF.
- 2) While observing the LEDs on OAM Logic Board; turn OAM Power Switch back ON.

Normal Result (A)

LED D1 ON Blinking; indicates the OAM liquid level sensor is functioning properly and the OAM Unit is operating in the **FILL** Mode. (So long as liquid is not present in the upper sight glass).

Faulty Result (B)...

LEDs D2 ON Blinking, D4 and D5 ON SOLID; means either the Liquid Level Sensor has erroneously detected a liquid level and is therefore defective, or the Logic Board is defective.

To determine which component is at fault proceed with the following test:

- 1) Again, turn OAM Power Switch OFF.
- 2) Disconnect the **Yellow** level sensor wire and the **Blue** Bleed Resistor wire from **Input Terminal IN2** on the OAM Logic Board. This eliminates the Level sensor from the circuit.
- 3) Turn the OAM Power Switch back ON.

Determination (1)

LED D1 ON Blinking; indicates the **Logic Board is responding** correctly therefore the problem is the Liquid Level Sensor.

Proceed to **Liquid Level Sensor Replacement Instructions** on page 47.

Determination (2)

Any other result indicates a bad board. Board must be replaced. (When replacing Board do not forget to re-connect the **Yellow** level sensor wire and the **Blue** Bleed Resistor wire to **Input Terminal IN2** on the OAM Logic Board.)

Liquid Level Sensor Replacement Instructions

Liquid Level Sensor malfunction can result from either a defective **Electronic Module** or a cracked or cloudy **Prism**. A faulty Electronic Module is most likely causing the problem and therefore should be replaced first since it can be replaced quickly and easily without opening the refrigeration system.

However, if after replacing the Electronic Module the Liquid Level Sensor still does not function properly then the **Prism is probably at fault**. A cracked or cloudy Prism can cause erratic response or no response at all to the presence of liquid.

If the Prism is defective the complete Liquid Level Sensor will have to be replaced. In order to replace the complete sensor it will be necessary to **isolate and depressurize the OAM Distillation Tank**.

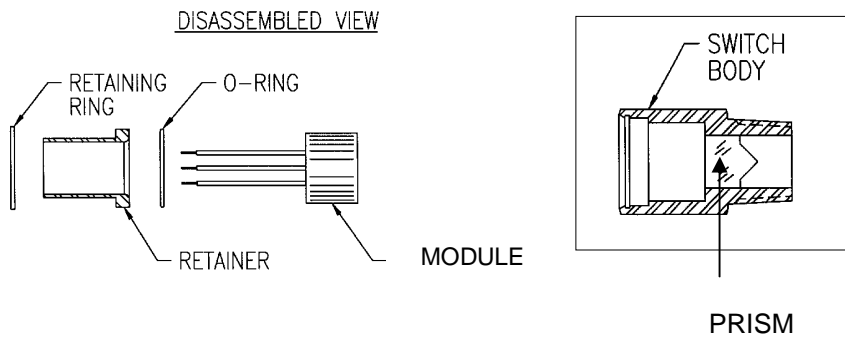

Replacing Level Sensor Switch Electronic Module...

- 1) Turn OAM Power Switch OFF.
- 2) Disconnect the **white** Liquid Level Sensor wire from TB-1 terminal 2, and the **black** sensor wire from TB-1 terminal 5.
- 3) Disconnect the **yellow** sensor wire from the Bleed Resistor connected to Input terminal IN2 on the Logic Board
- 4) Remove sensor wiring and conduit from electrical box.
- 5) Remove conduit and conduit connector from sensor.
- 6) Remove the Retaining Ring that holds the Electronic Module in place in the sensor body. This will require a pair of IRR P-101 or equivalent snap ring pliers.
- 7) Remove the retainer
- 8) Using the module leads gently pull the defective module and O-ring from the sensor body, being careful not to loose the O-ring.
- 9) Insert the new replacement module with old O-ring into the sensor body.
- 10) Insert retainer and re-install retaining ring.
- 11) Re-connect sensor wires.

NOTE: It is imperative that the white wire be connected to TB-1 terminal 2 and the black wire be connected to TB-1 terminal 5. The yellow wire must be connected to the Blue Bleed Resistor wire and both must be connected to Logic Board Input terminal IN2.

PROCEDURE TO CLEAR OIL LOGGED DISTILLATION TANK

The following conditions can cause “oil logging” of the OAM Purger Distillation Tank:

1. The oil sump “**Oil Charging**” valve has been inadvertently left closed.
2. The “**Oil Return**” Solenoid Valve (SOL-3) fails in the closed position.
3. “**Relay (RLY-3)**” fails to energize Solenoid Valve (SOL-3) preventing oil return to oil sump.
4. The “**Oil Return**” line is kinked, or obstructed, preventing oil return to oil sump. 2
5. The **Pressure Equalization Check Valve is defective** preventing the OAM from retaining pressure that is used to return oil to the oil sump during the oil return phase.

Should oil logging occur, clear the Distillation Tank using the following procedure:

1. Troubleshoot the purger to determine which of the above mentioned conditions has caused the oil logging problem.
2. Correct the problem. Only after the problem has been corrected can you proceed to the next step.
3. Turn OFF power to purger.
4. Isolate the purger from the Chiller by closing **all** valves to purger: Refrigerant Charging Valve, Oil Sump Charging Valve and the Evaporator Gauge Stop Valve.
5. Remove cover from Electrical Panel, on **Switch SW2** flip **Dip Switch 3** to the **ON** position. (***This procedure allows the Oil Return Solenoid Valve (SOL-3) ONLY to energize when power is reapplied.***) (See Figure 6, on page 33 for location of SW2.)
6. Using a manifold gauge set, connect a pressure source, such as nitrogen, to the Shrader Access Fitting located near the top of the Distillation Tank. Pressurize the tank to approximately **5 psig**.
7. Now, **RE-OPEN** the oil sump oil-charging valve.
8. Turn power to purger back **ON**.
9. The 5 psig pressure will now push the oil from the Distillation Tank back to the Chiller’s oil sump.
10. When the manifold gauge indicates 2 psig pressure in the Distillation Tank, enough oil has been transferred. Be sure to stop at 2 psig to prevent nitrogen from entering the Chiller.
11. Remove manifold gauge set from purger.
12. Turn power to purger back **OFF** again.
13. Flip **SW2, dip switch 3** back to the **OFF** position. (See Figure 6, on page 33 for location of SW2.)
14. Use vacuum pump to evacuate the OAM Purger.
15. Place cover back on electrical panel.
16. **OPEN ALL** valves to purger.
17. Turn power to purger back **ON**. The OAM Purger should now function properly.

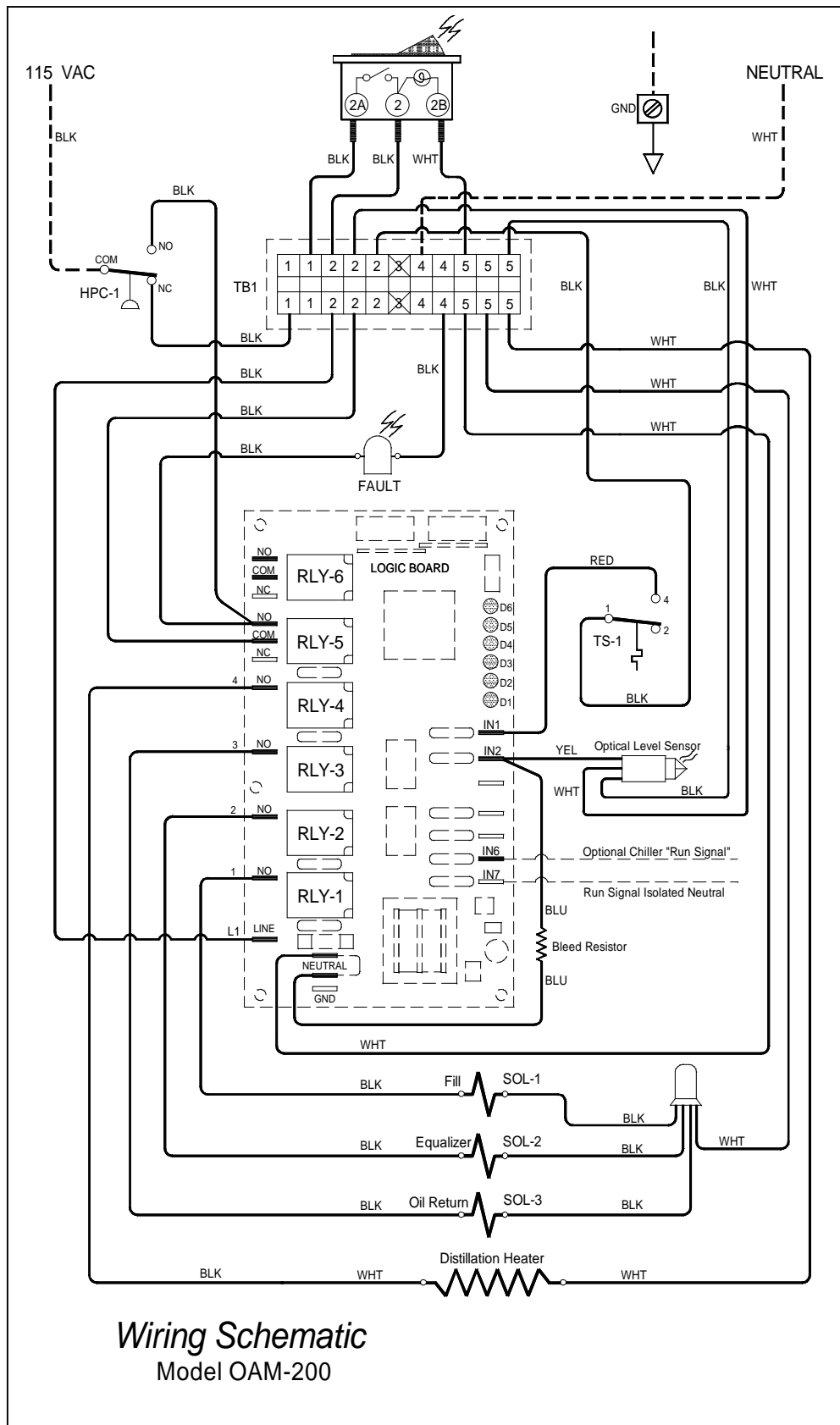

Figure 8. – Electrical wiring diagram