

Trouble Shooting

NOTE: Should the OAM Purger shut down on a FAULT condition, DO NOT POWER OFF THE PURGER until you have first removed the electrical panel cover and recorded the status of the indicator LED's D1 through D5 located on the Logic Board. Knowing the particular LED(s) that are lighted will help you diagnose the cause of the problem. Once the unit is powered off, this information will be lost. Retain the record of the LED readings. Examine the purger for any apparent problems, check the troubleshooting section for possible causes of the fault. **Check to see if all appropriate Dip Switches on SW1 & SW2 are off (see pages 23, 33 and 40), then if there is no readily apparent problem, you should reset one time (and only one time) to see if the fault repeats.**

Trouble-shooting Chart

Symptom	Possible Cause	Solution
Power switch ON but switch Light is Off.	L` hmonv dqs n t ntsNæ Rv tsbg kfi gscdæbstud-	Qdr snqf l` hmonv dq Qdok bd Rv tsbg-
Power switch ON and lighted but Logic Board LED's are all OFF.	Knf lb An` q æ r d akv m Knf lb An` q cdæbstud-	Qdok bd æ r d- Qdok bd Knf lb An` q-
Red Fault LED D6 ON and flashing with Green LED D1 ON solid. Indicates distillation temperature did not drop below 145 degrees F during the first 14 minutes of the fill phase.	Chr stk stnmgd` sdqr st bj nm QKX,0 bnns bsr r st bj - Sdl odq st qf Rdmr nqSR,0 cdæbstud- Bgthdqf bg` q hmf u` kud bknr dc- NtkQds qmRnkdmrte U` kud RNK,1 cdæbstud` mæ sgd ot qf dqg` r adbnl d ntk knf f dc- QKX,3 qk x v gthg bnnsqnr NtkSq m ædq Rnkdmrte 'RNK,1(cdæbstud- Bgthdqf ntkrt l o bg` q hmf u` kud bknr dc b` tr hmf ot qf dqs adbnl d ntkknf f dc-	Qdok bd Knf lb An` q- Qdok bd r dmr nq Nodmu` kud- Rdd bld` qmrf ntkknf f hmf oqbdct qf o` f d 28- Qdok bd r nkdmrte u` kud Qdok bd Knf lb An` q- NodmU` kud` mæ rdd o` f d 28 æq bld` qmrf Ntkknf f hmf -

Trouble-shooting Chart (continued)

Symptom	Possible Cause	Solution
<p>Red Fault LED D6 flashing with Green LED D2 ON solid.</p> <p>Indicates distillation temperature failed to reach 145 Degrees F within 4 hours after entering Primary Distillation Phase.</p>	<p>Distillation heater defective.</p> <p>Heater relay RLY-1 on Logic Board defective.</p> <p>Temperature Sensor TS-1 defective.</p>	<p>Replace heater (see Maintenance Using Switch SW2 dip switch 4 as a diagnostic aid See page 40).</p> <p>Replace Logic Board.</p> <p>Replace Temperature Sensor (TS-1).</p>
<p>Red Fault LED D6 flashing with Green LED D3 ON solid.</p> <p>Indicates the purger Logic Board did not see any activations of Equalization Solenoid Valve SOL-1 during distillation phases.</p>	<p>Heater may be defective.</p> <p>Oil Return Solenoid Valve Sol-2 failed open or closed.</p> <p>Relay RLY-4 contacts failed open or closed.</p> <p>Pressure Equalization Solenoid Valve (SOL-1) failed open or closed.</p> <p>RLY-3 failed open or closed.</p> <p>Purger may be mounted to high.</p> <p>Fill Check Valve CK-2 stuck in open position.</p> <p>Refrigerant Charge low.</p> <p>Differential Pressure Switch DPS-1 defective.</p> <p>Dip Switches on Switches SW1 or SW2 may be set improperly</p> <p>Fill line may not be insulated properly</p>	<p>Replace Heater</p> <p>Replace valve.</p> <p>Replace Logic Board.</p> <p>Replace Valve.</p> <p>Replace Logic Board.</p> <p>See Mounting Section Page 13, 14.</p> <p>Replace Check Valve CK-2.</p> <p>Correct Refrigerant Charge.</p> <p>Replace Switch.</p> <p>See page 23, 33 and 40 for SW1 and SW2 information.</p> <p>Insulate fill line to Chiller shell.</p>
<p>Red Fault LED D6 flashing with Green LED D4 ON solid.</p> <p>Indicates the Logic Board did not see at least 2 activations of Equalization Solenoid Valve SOL-1 during the distillation Phases.</p>	<p>Heater may be defective.</p> <p>Pressure Equalization Solenoid Valve SOL-1 failed open or closed.</p> <p>Fill Check Valve CK-2 stuck open</p> <p>Differential Pressure Switch defective.</p> <p>Oil Return Solenoid Valve SOL-2 failed open.</p> <p>RLY-4 Contacts stuck.</p> <p>RLY-3 contacts failed open or closed.</p> <p>Refrigerant Charge low.</p> <p>Purger may be mounted to high.</p> <p>Dip Switches on Switches SW1 or SW2 may be set improperly.</p> <p>Fill line may not be insulated properly</p>	<p>Replace Heater.</p> <p>Replace Valve.</p> <p>Replace Check Valve CK-2.</p> <p>Replace switch.</p> <p>Replace Valve.</p> <p>Replace Logic Board.</p> <p>Replace Logic Board.</p> <p>Correct Refrigerant Charge.</p> <p>See Mounting Section Page 13, 14.</p> <p>See page 23, 33 and 40 for SW1 and SW2 information.</p> <p>Insulate fill line to Chiller shell.</p>

Trouble-shooting Chart (continued)

Symptom	Possible Cause	Solution
Distillation Heater doesn't get hot.	Defective Heater. RLY-1 relay defective. Disconnected lead. Defective Temperature Sensor TS-1. Contacts stuck closed.	Replace heater (See Maintenance Section on Using Switch SW2 DIP switch 4 as a diagnostic aid.) Replace Logic Board. Reconnect lead. Replace Sensor.
Equalization Solenoid Valve SOL-1 fails to open or close.	SOL-1 Solenoid Valve defective. RLY-3 relay defective. Disconnected lead. Differential Pressure Switch DPS-1 defective.	Replace valve. Replace Logic Board. Reconnect lead. Replace switch.
Oil Return Solenoid Valve SOL-2 fails to open or close.	SOL-2 Solenoid Valve defective. RLY-4 relay defective. Disconnected lead.	Replace valve. Replace Logic Board. Reconnect lead.
Distillation Tank will not fill.	Chiller's refrigerant charging valve closed. Vapor return line isolation valve closed. Equalization Solenoid Sol-1 failed to energize. Distillation Heater stuck ON during Fill Phase. Distillation Tank oil logged. Fill line kinked or obstructed. Fill line strainer clogged. Fill Check valve CK-2 fails to open. Purger may be mounted too high. Fill line and connecting piping up to evaporator shell may not be insulated causing vapor lock. Refrigerant Charge low.	Open Valve. Open Valve. Replace Equalization Solenoid Sol-1. Defective TS-1, Replace. Or RLY-1 contacts stuck. Replace Logic Board. See "Maintenance" section for procedure to clear oil logged distillation tank. Correct as needed. Replace Fill line Strainer. Replace Check Valve CK-2. See Mounting Section Page 13, 14. Insulate, (see page 17 for warning information on insulating.) Correct Refrigerant Charge.

Trouble-shooting Chart (continued)

Symptom	Possible Cause	Solution
Oil will not transfer from Distillation Tank to oil sump.	Oil Return Solenoid Valve SOL-2 Solenoid defective. Oil Sump valve closed. Oil return line kinked or blocked. Oil Filter blocked. RLY-4 relay defective. Equalization Solenoid Valve SOL-1 stuck open or leaking past valve seat.. RLY-3 relay contacts welded closed. Differential Pressure Switch DPS-1 defective. Fill Check Valve CK-2 stuck open.	Replace valve. Open Valve. Correct as necessary. Replace oil filter. Replace Logic Board. Replace valve. Replace Logic Board. Replace DPS-1. Replace Fill Check Valve CK-2.
NO PRESSURE IN DISTILLATION TANK TO PUSH OIL to oil sump:	Equalization Solenoid Valve SOL-1 stuck open or leaking past valve seat.. Oil Return Solenoid Valve SOL-2 Solenoid defective. Differential Pressure Switch DPS-1 defective. Fill Check Valve CK-2 stuck open. RLY-4 relay defective. RLY-3 relay contacts welded closed. Distillation Tank oil logged.	Replace valve. Replace valve. Replace Differential Pressure Switch DPS-1. Replace Fill Check Valve CK-2. Replace Logic Board. Replace Logic Board. See "Maintenance" section for procedure to clear oil logged distillation tank.

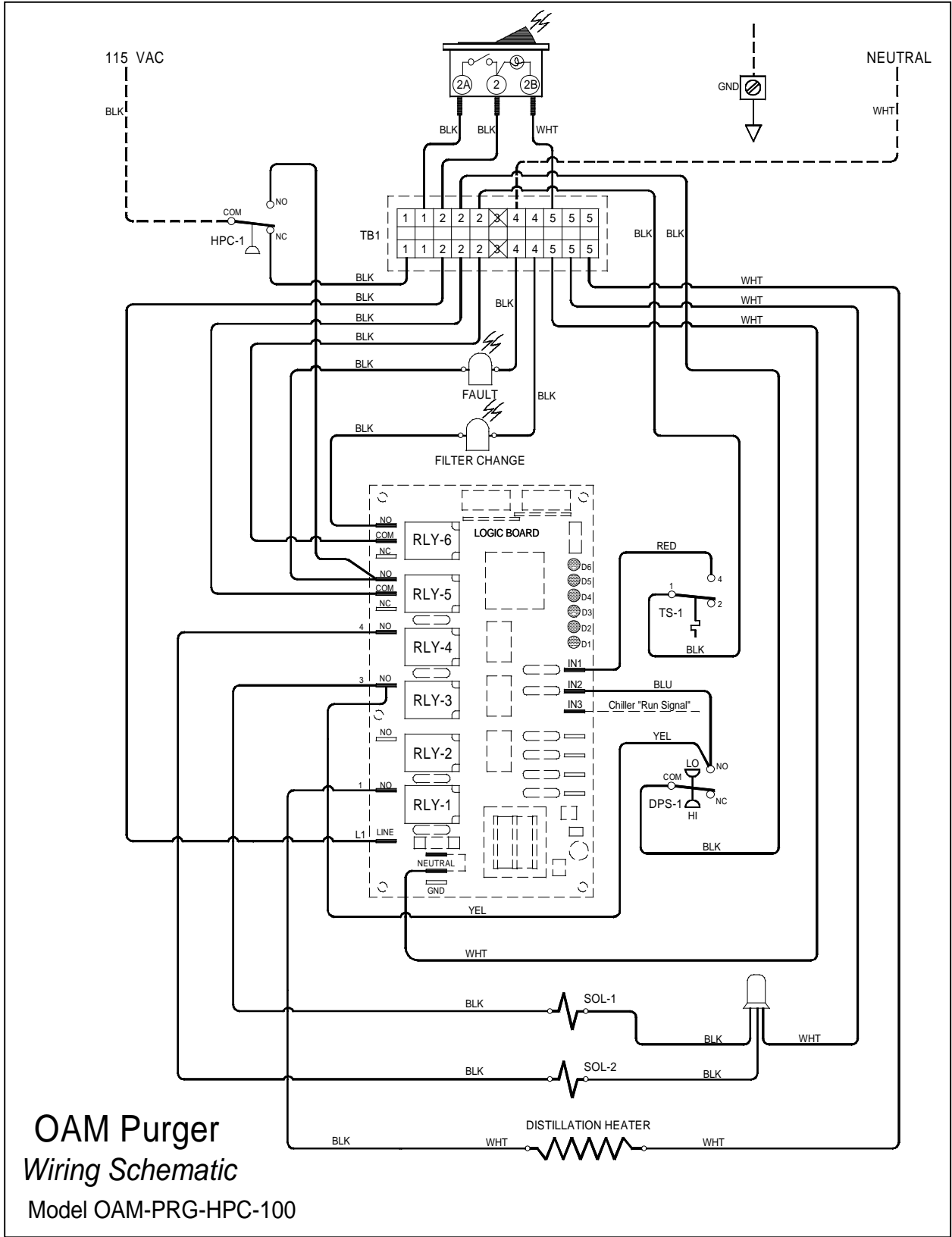

Figure 9. - Electrical wiring diagram